



**SPLIT TYPE
AIR CONDITIONER (50Hz)**

DUCT type

SERVICE MANUAL

Models	Indoor unit	Outdoor unit
	ARG7FUAB	AOG7FSAJ
	ARG7UUAB	AOG7USAJL
	ARG9FUAB	AOG9FSAJ
	ARG9UUAB	AOG9USAJL



C O N T E N T S

SPECIFICATIONS	1
OUTLINE AND DIMENSIONS	2
CIRCUIT DIAGRAM	3
REFRIGERANT SYSTEM DIAGRAM	5
ERROR CONTENTS	7
INDOOR P. C. BOARD CIRCUIT DIAGRAM	8
DISASSEMBLY ILLUSTRATION	10
PARTS LIST	18



Большая библиотека технической документации

<https://splitsystema48.ru/instrukcii-po-ekspluatacii-kondicionerov.html>

каталоги, инструкции, сервисные мануалы, схемы.

S P E C I F I C A T I O N S

INDOOR UNIT		ARG7FUAB	ARG7UUAB	ARG9FUAB	ARG9UUAB
OUTDOOR UNIT		AOG7FSAJ	AOG7USAJL	AOG9FSAJ	AOG9USAJL
COOLING CAPACITY	(kW)	2.15	2.15	2.80	2.70
HEATING CAPACITY	(kW)	—	2.45	—	3.10

ELECTRICAL DATA

POWER SOURCE	(V)	230				
FREQUENCY	(Hz)	50				
RUNNING CURRENT	(A)	COOLING	3.7	3.6	4.6	4.4
		HEATING	—	3.6	—	4.5
INPUT WATTS	(kW)	COOLING	0.76	0.76	0.99	0.96
		HEATING	—	0.76	—	0.96
E.E.R.	(kW/kW)	COOLING	2.83	2.83	2.83	2.81
		HEATING	—	3.22	—	3.23
MOISTURE REMOVAL	(ℓ/hr)	0.8	0.8	1.0	1.0	
AIR CIRCULATION-Hi	(m³/hr)	340	340	420	420	

COMPRESSOR

TYPE	ROTARY			
CODE	80210065(B)	80210065(B)	80214165(B)	80214165(B)

FAN MOTOR

TYPE	INDOOR UNIT	MFA-9NTAT			
	OUTDOOR UNIT	MFB-14VTT	MFB-14NTT	MFB-14VTT	MFB-14NTT
POWER SOURCE	(V)	230			
HI-SPEED	(r.p.m.)	710	710	855	855
MED-SPEED	(r.p.m.)	675	675	780	780
LO-SPEED	(r.p.m.)	625	625	735	735

DIMENSIONS

INDOOR UNIT	H x W x D (mm)	217 x 663 x 595			
OUTDOOR UNIT		530 x 750 x 250			

WEIGHT

INDOOR UNIT	GROSS / NET (kg)	22 / 18			
OUTDOOR UNIT		29 / 27	30 / 28	29 / 27	32 / 30

REFRIGERANT CHARGE (R410A)

PIPE LENGTH		7.5 m (25 ft)	10 m (33 ft)	15 m (49 ft)	Additional refrigerant 15 g / m (0.53 oz / 3.3 ft)
FULL CHARGE AMOUNT	ARG7FUAB	550 g (19.4 oz)	587.5 g (20.7 oz)	662.5 g (23.4 oz)	
	ARG7UUAB	650 g (22.9 oz)	687.5 g (24.2 oz)	762.5 g (26.9 oz)	
	ARG9FUAB	600 g (21.2 oz)	637.5 g (22.5 oz)	712.5 g (25.2 oz)	
	ARG9UUAB	750 g (26.5 oz)	787.5 g (27.8 oz)	862.5 g (30.5 oz)	

OUTLINE AND DIMENSIONS

INDOOR UNIT

(unit : mm)

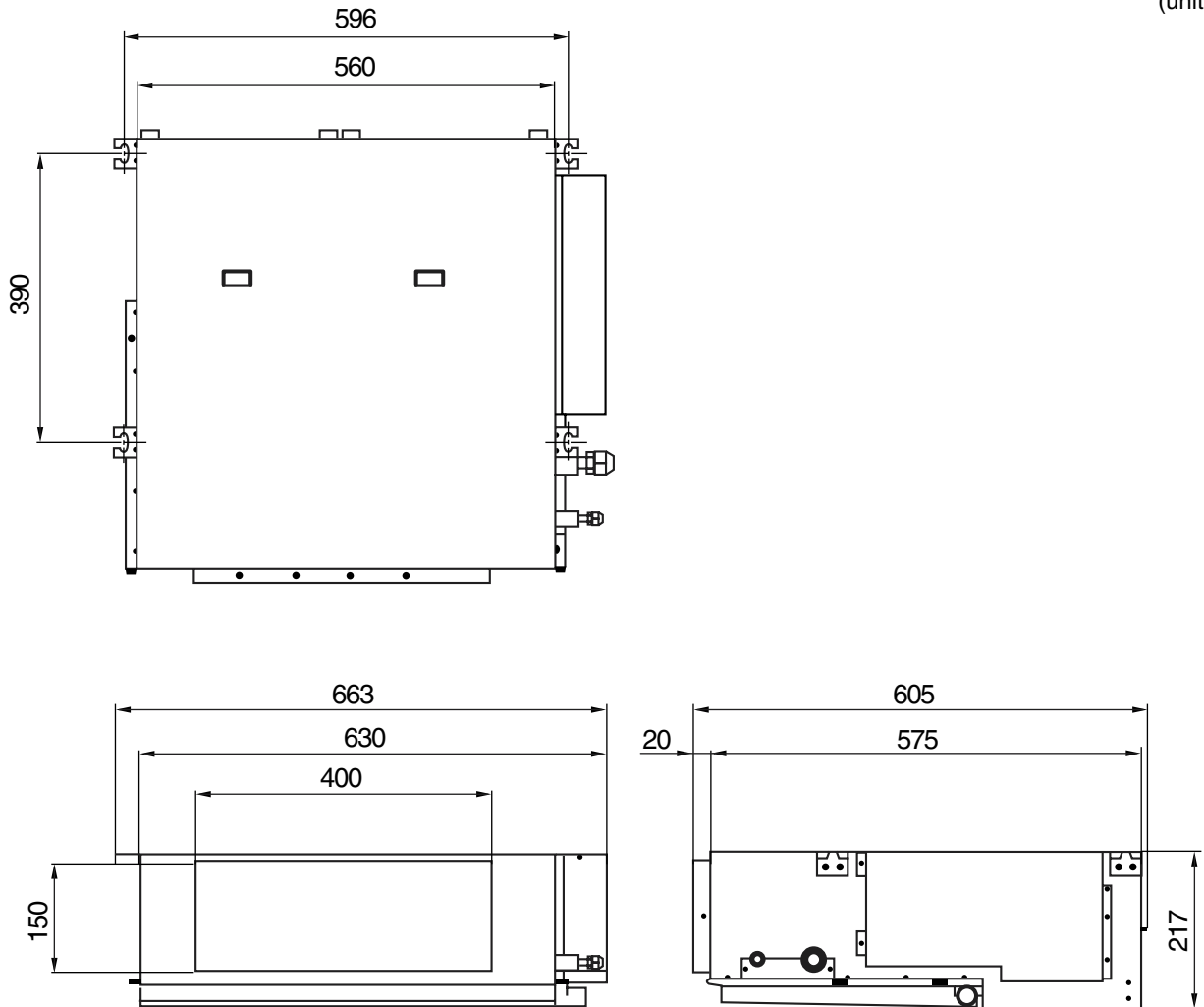

OUTDOOR UNIT

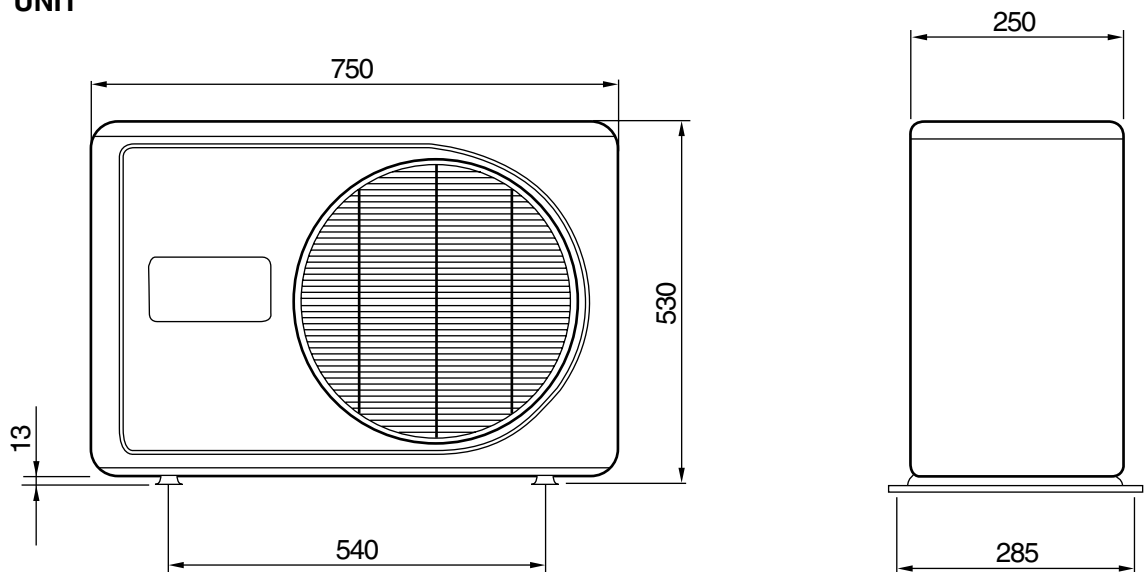

CIRCUIT DIAGRAM

Models : ARG7FUAB / AOG7FSAJ
 ARG9FUAB / AOG9FSAJ

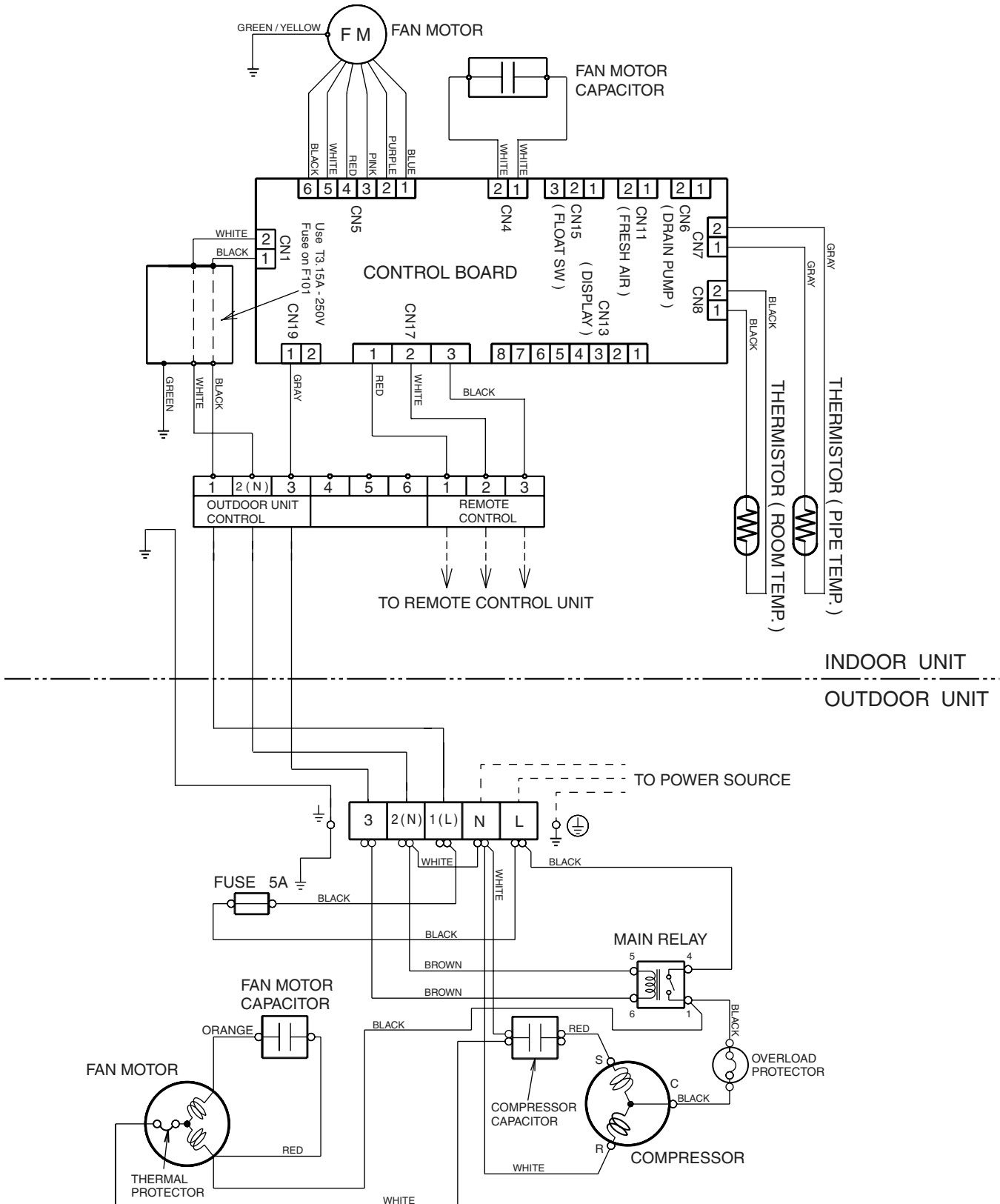

**Models : ARG7UUAB / AOG7USAJL
ARG9UUAB / AOG9USAJL**

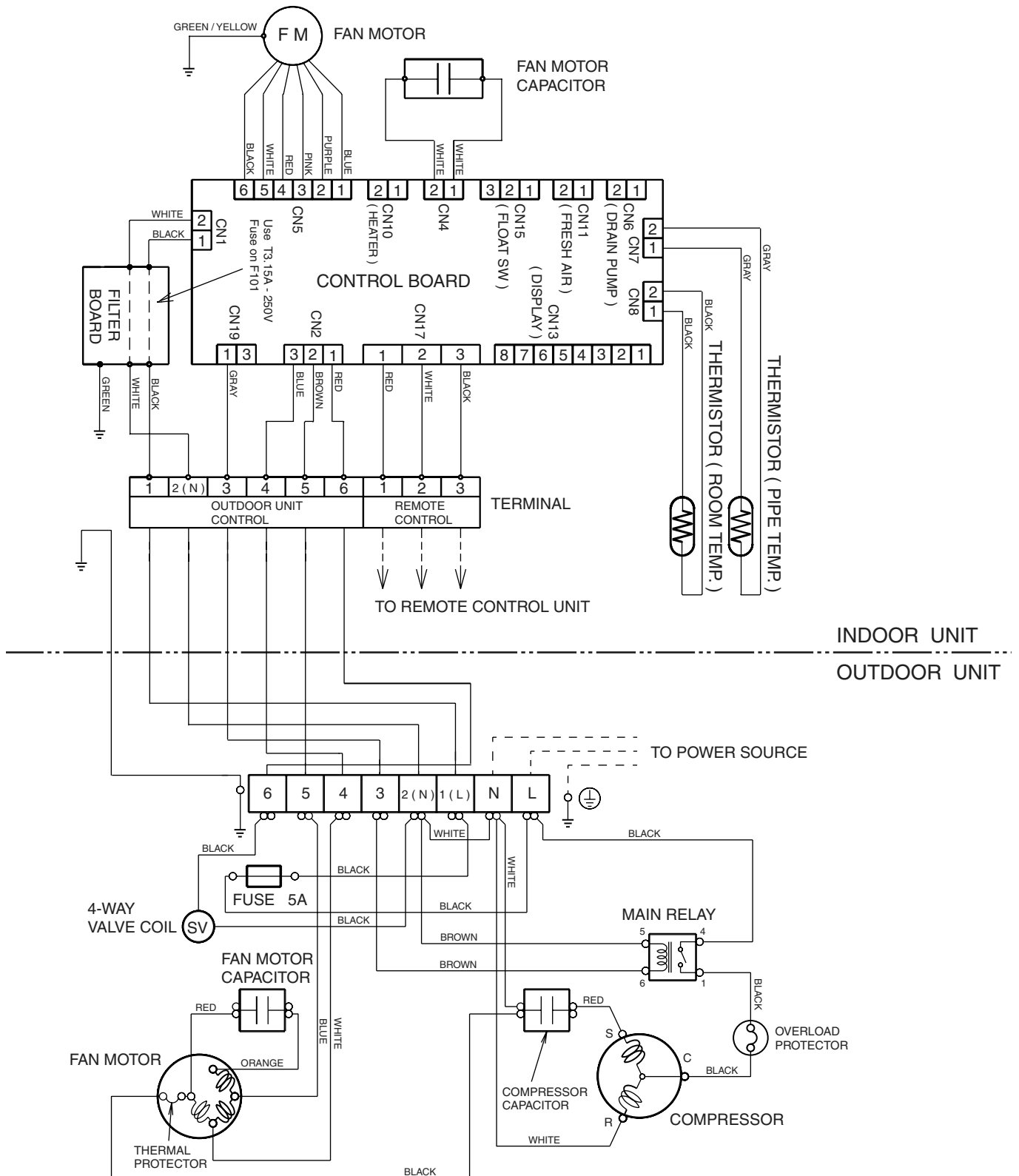

REFRIGERANT SYSTEM DIAGRAM

Models : ARG7FUAB / AOG7FSAJ
ARG9FUAB / AOG9FSAJ

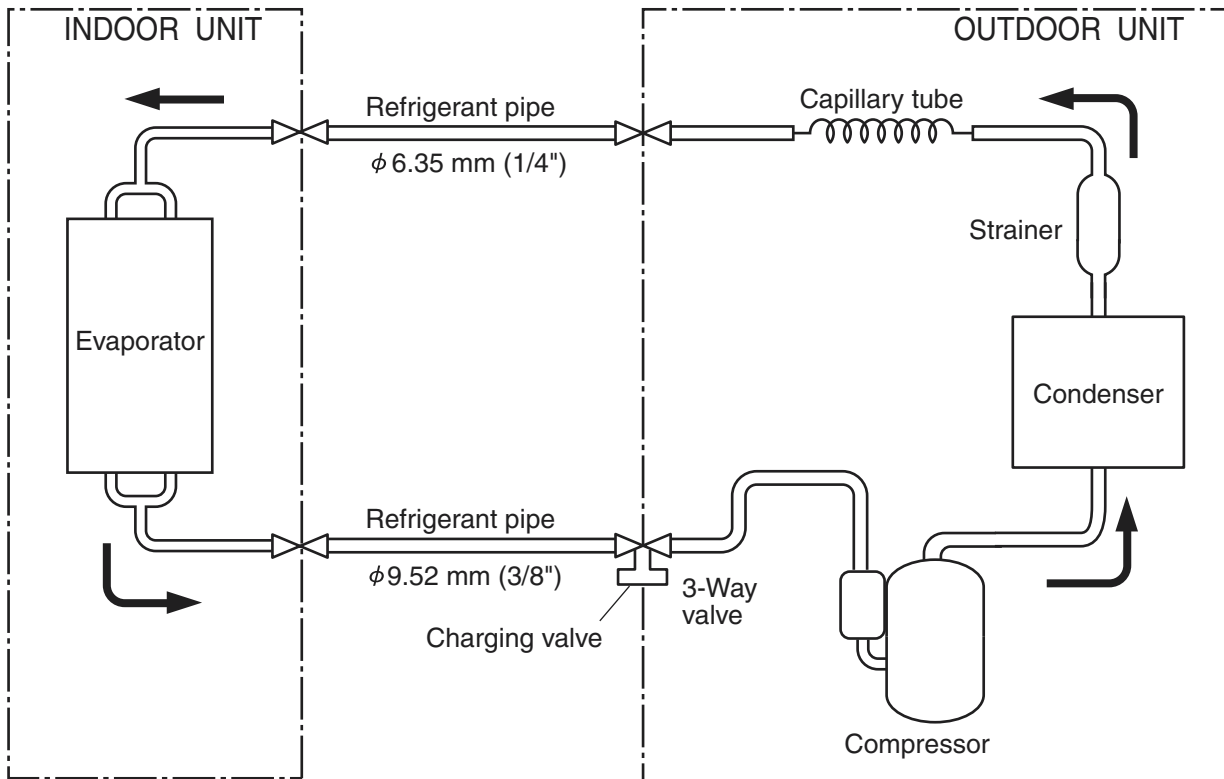

Models : ARG7UUAB / AOG7USAJL

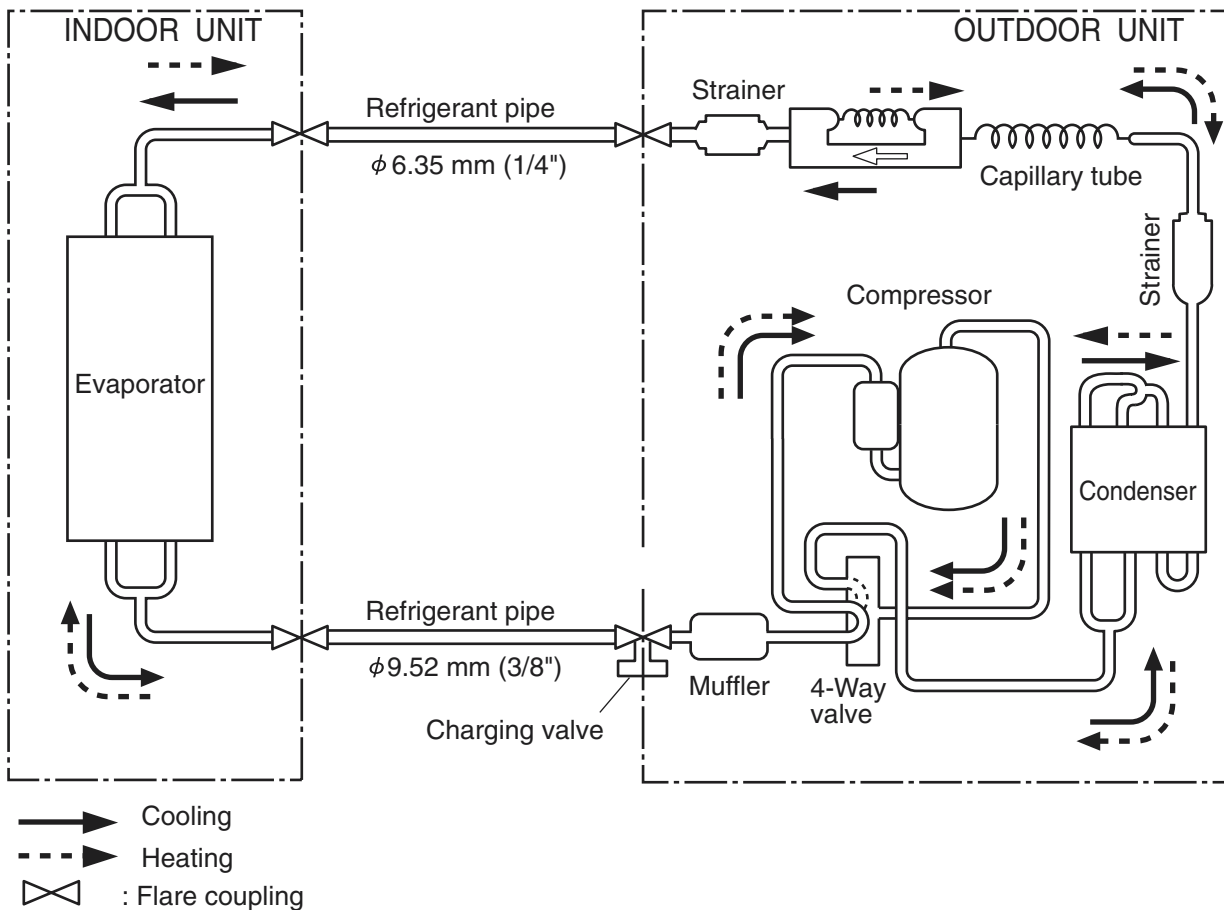

Models : ARG9UUAB / AOG9USAJL

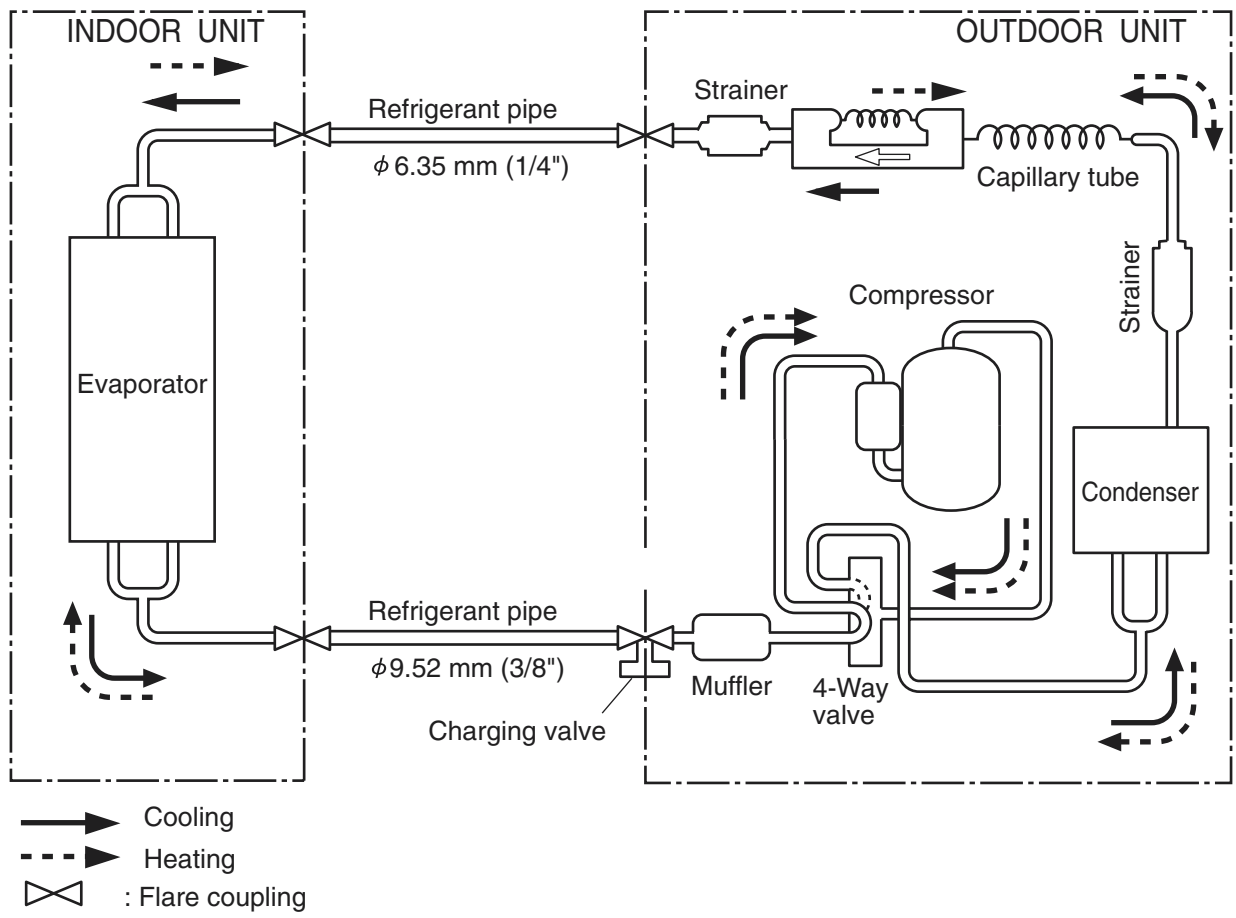

ERROR CONTENTS

- (1) Stop the air conditioner operation.
- (2) Press the master control button and the fan control button simultaneously for 2 seconds or more to start the test run.

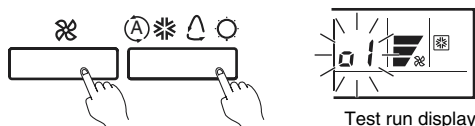

- (3) Press the start/stop button to stop the test run.

[SELF-DIAGNOSIS]

When the error indication "E:EE" is displayed, follow the following items to perform the self-diagnosis.

"E:EE" indicates an error has occurred.

1. REMOTE CONTROLLER DISPLAY

- (1) Stop the air conditioner operation.
- (2) Press the set temperature buttons Δ / ∇ simultaneously for 5 seconds or more to start the self-diagnosis.

Refer to the following tables for the description of each error code.

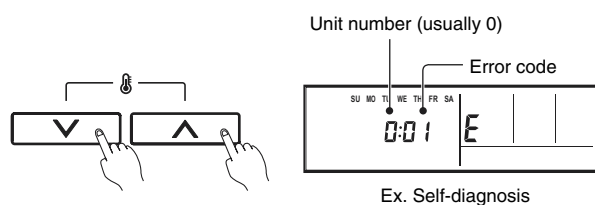

- (3) Press the set temperature buttons Δ / ∇ simultaneously for 5 seconds or more to stop the self-diagnosis.

Error code	Error contents
00	Communication error (indoor unit ↔ remote controller)
01	Communication error (indoor unit ↔ outdoor unit)
02	Room temperature sensor open
03	Room temperature sensor short-circuited
04	Indoor heat exchanger temperature sensor open
05	Indoor heat exchanger temperature sensor short-circuited
06	Outdoor heat exchanger temperature sensor open
07	Outdoor heat exchanger temperature sensor short-circuited
08	Power source connection error
09	Float switch operated
0A	Outdoor temperature sensor open
0B	Outdoor temperature sensor short-circuited
0C	Discharge pipe temperature sensor open
0D	Discharge pipe temperature sensor short-circuited
0E	Outdoor high pressure abnormal
0F	Discharge pipe temperature abnormal
11	Model abnormal
12	Indoor fan abnormal
13	Outdoor signal abnormal
14	Outdoor EEPROM abnormal

INDOOR PRINTED CIRCUIT BOARD CIRCUIT DIAGRAM

**Models : ARG7FUAB
ARG9FUAB**

CONTROLLER PCB ASSEMBLY (MAIN PCB)
ARG7FUAB : EZ-00307WSE-C
ARG9FUAB : EZ-00308WSE-C

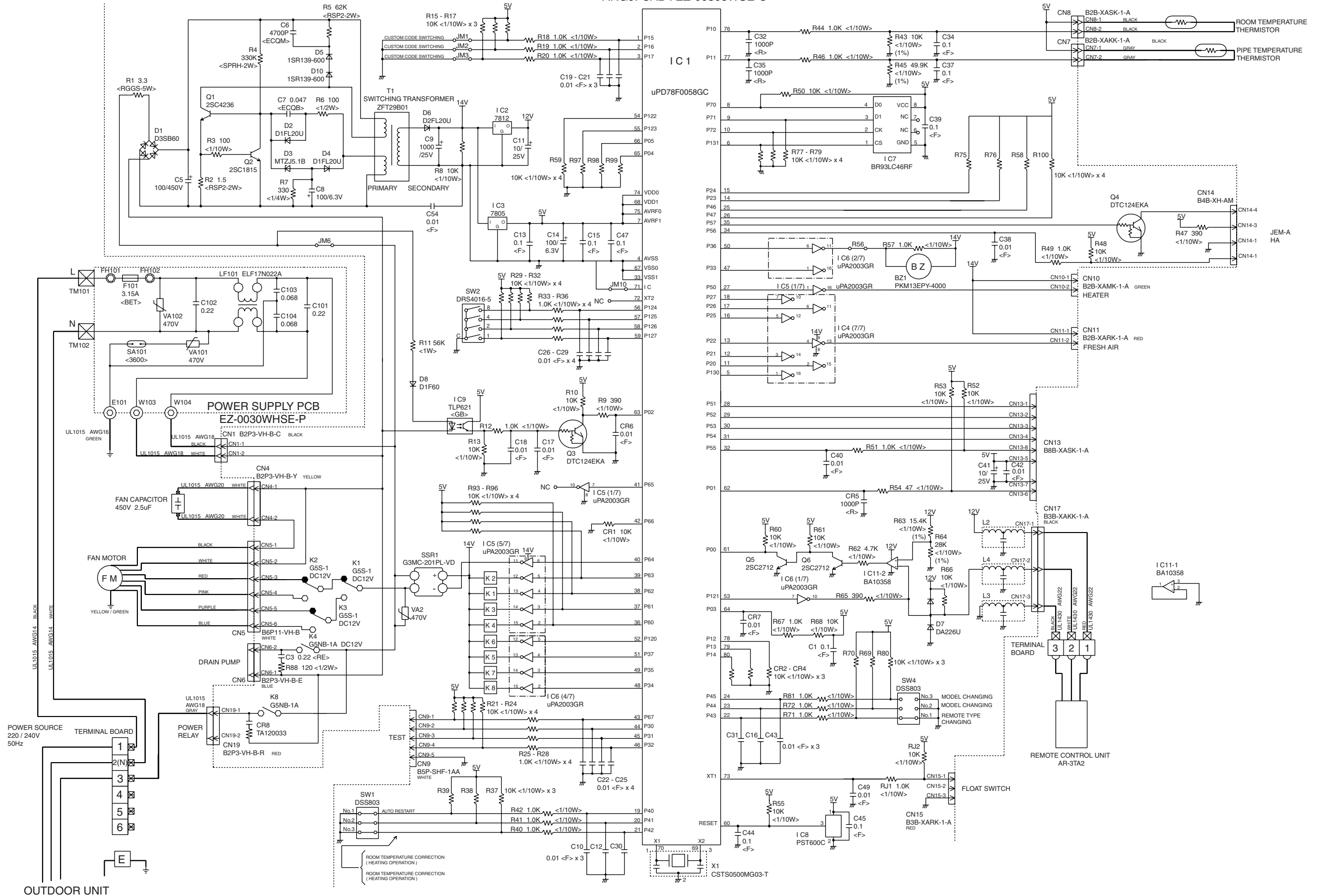

Models : ARG7UUB
ARG9UUB

CONTROLLER PCB ASSEMBLY (MAIN PCB)
ARG7UUB : EZ-00323HSE-C
ARG9UUB : EZ-00322HSE-C

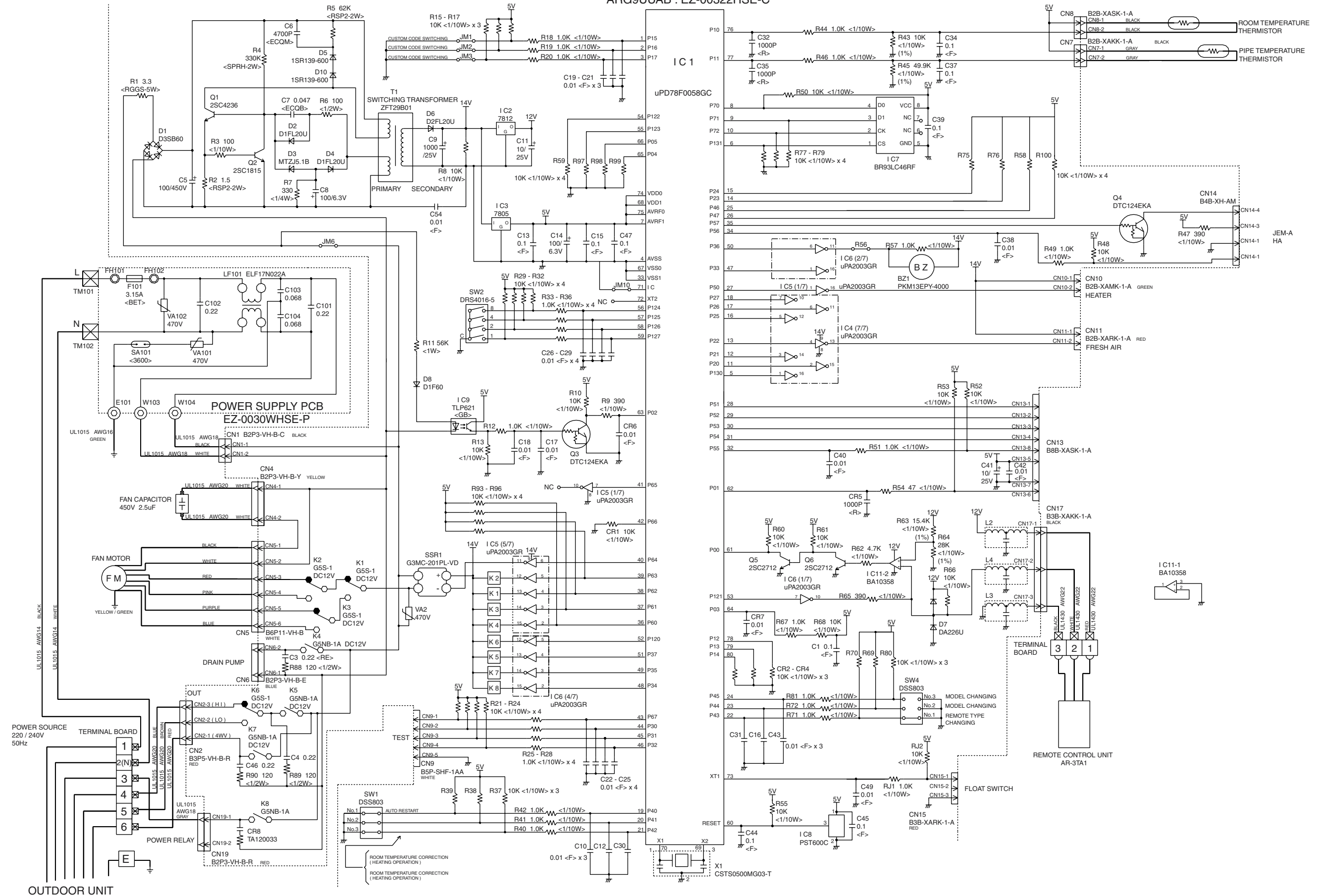

DISASSEMBLY ILLUSTRATION

Models : ARG7FUAB
ARG7UUAB
ARG9FUAB
ARG9UUAB

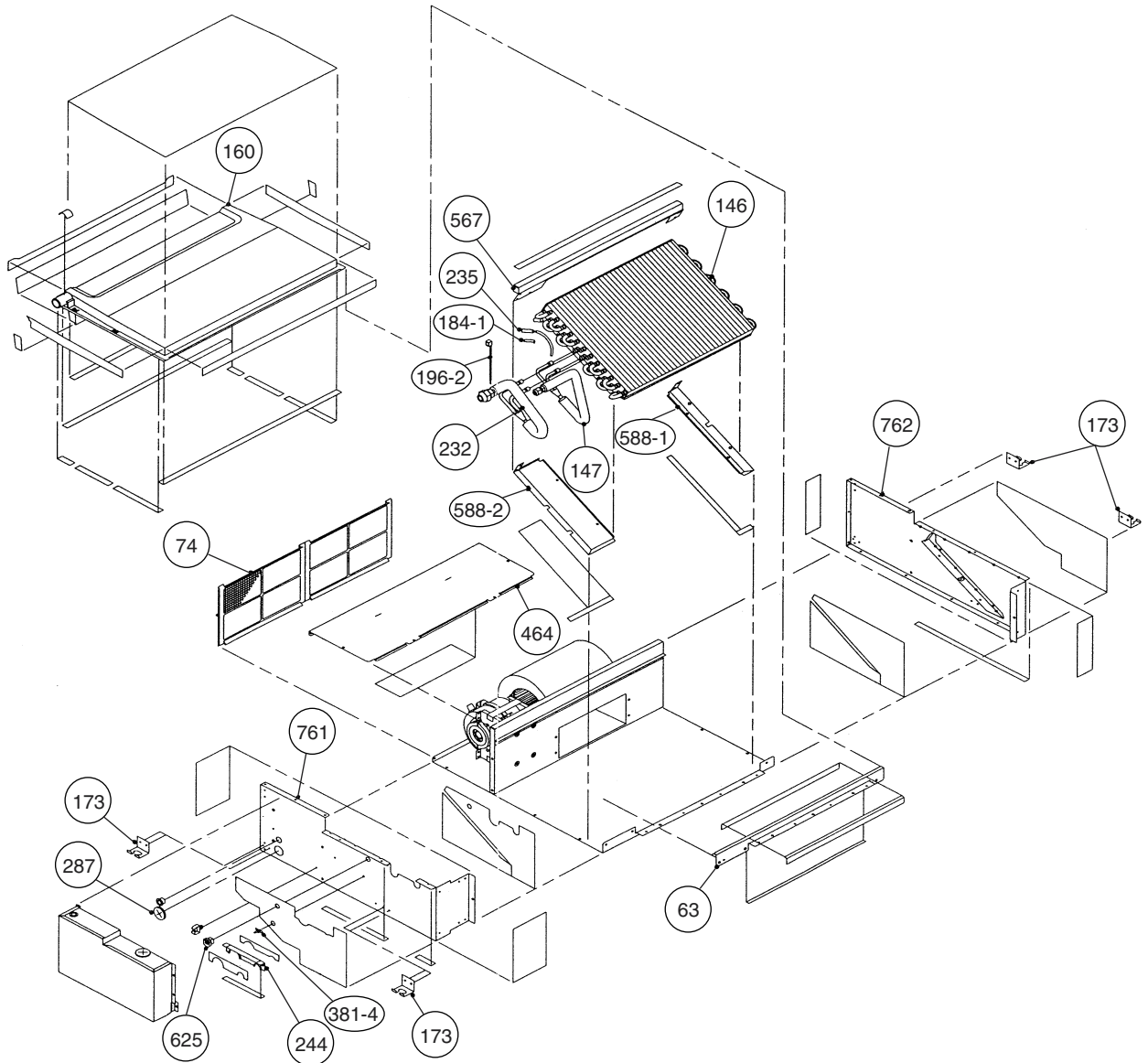

Models : ARG7FUAB
ARG7UUAB
ARG9FUAB
ARG9UUAB

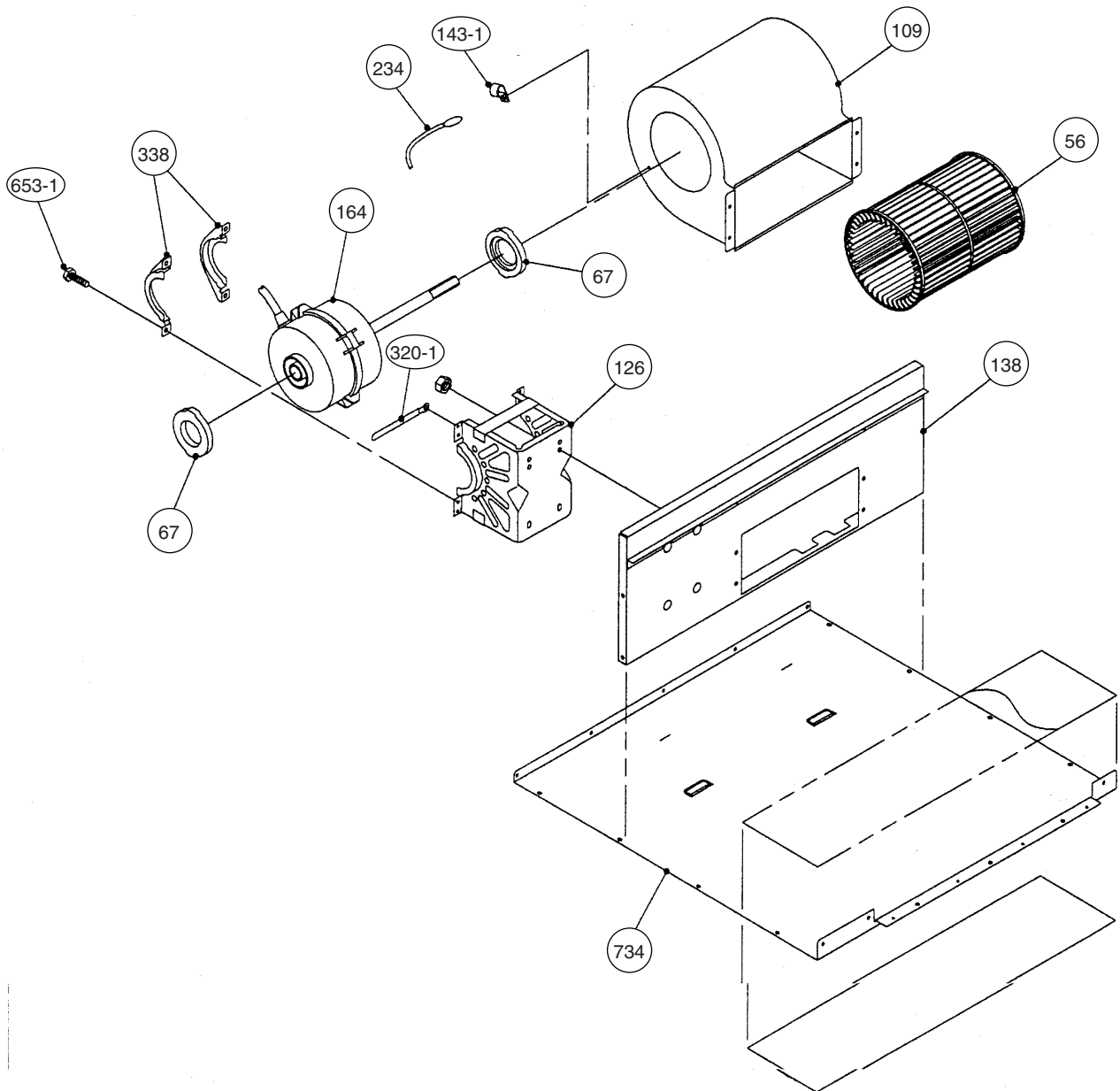

**Models : ARG7FUAB
ARG7UUAB
ARG9FUAB
ARG9UUAB**

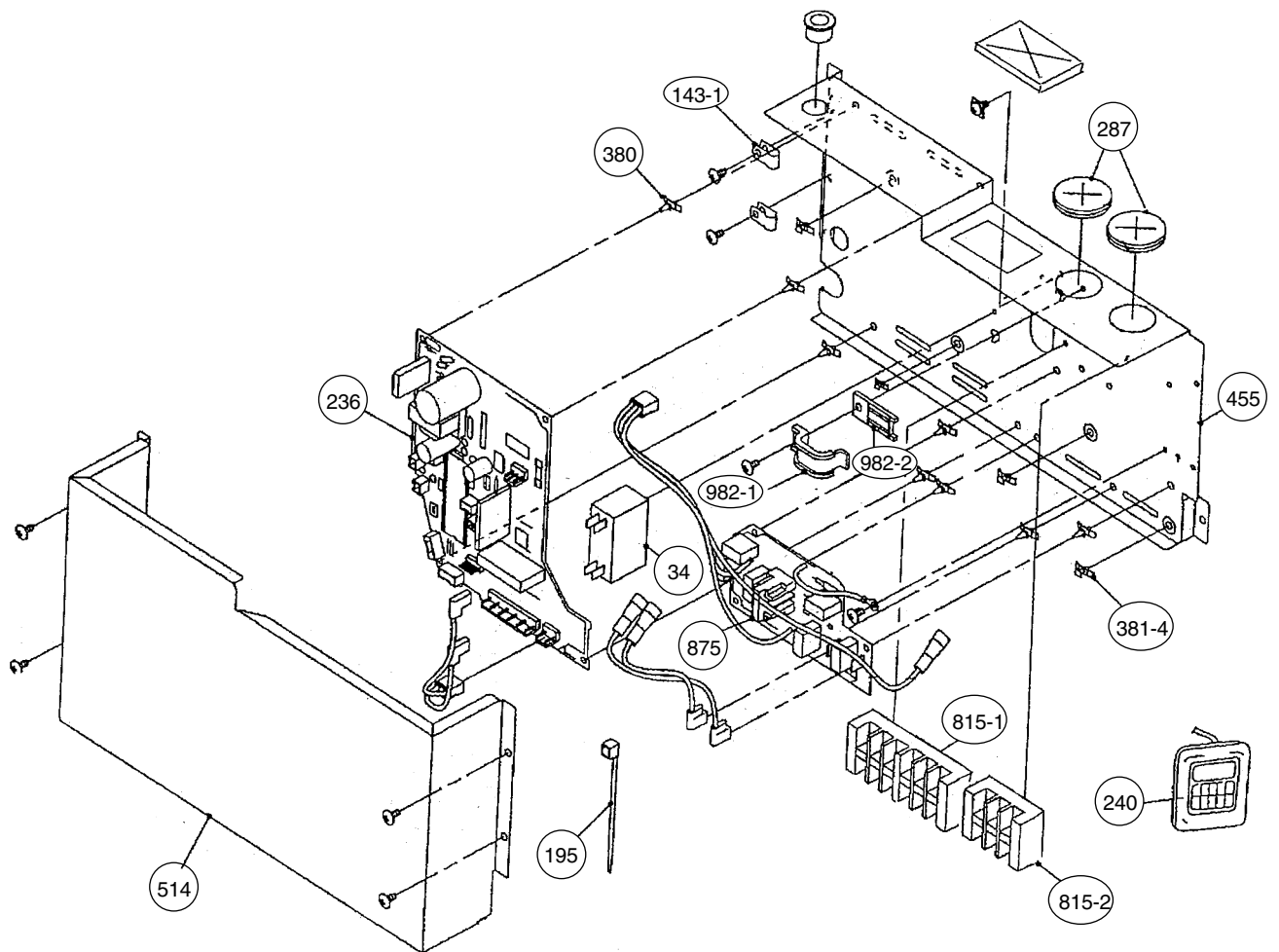

Models : AOG7FSAJ
AOG7USAJL
AOG9FSAJ
AOG9USAJL

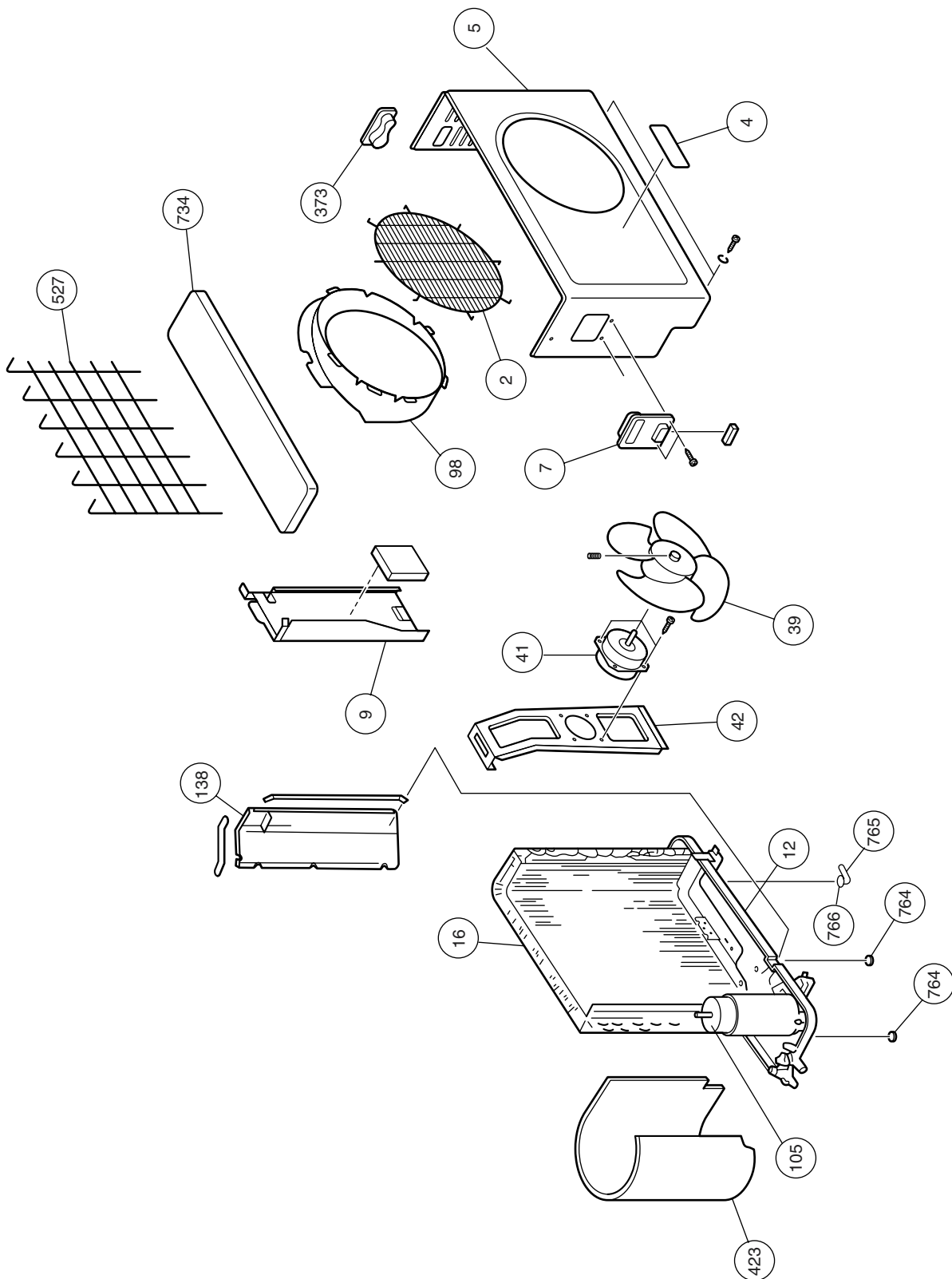

**Models : AOG7FSAJ
AOG9FSAJ**

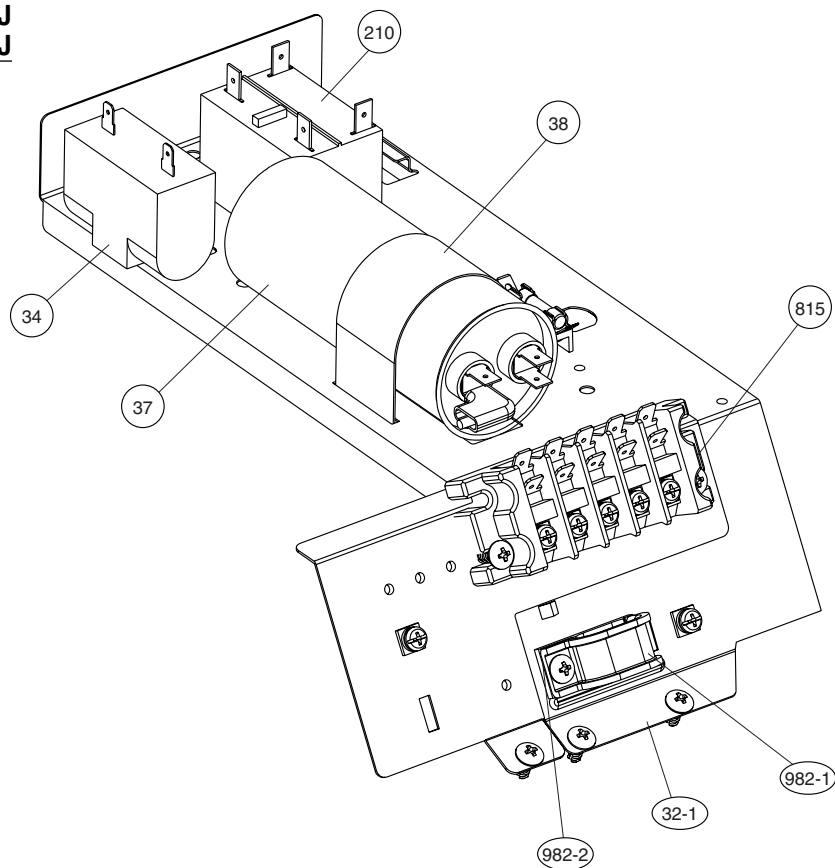

**Models : AOG7USAJL
AOG9USAJL**

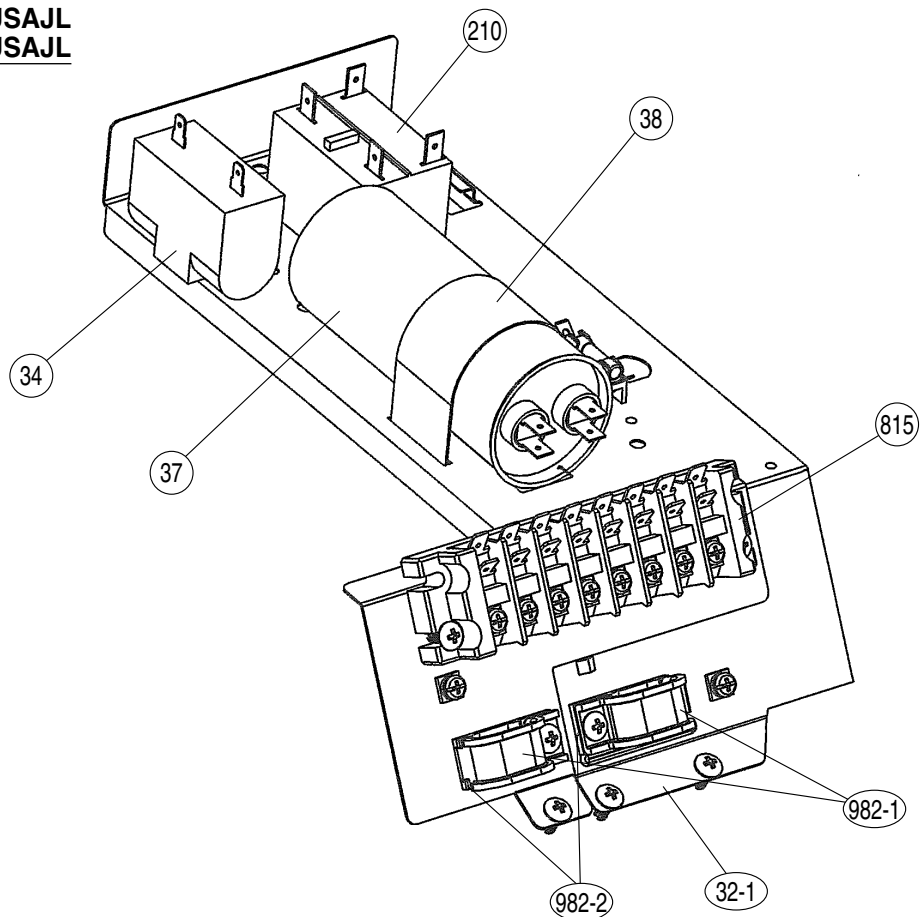

Models : AOG7FSAJ
AOG9FSAJ

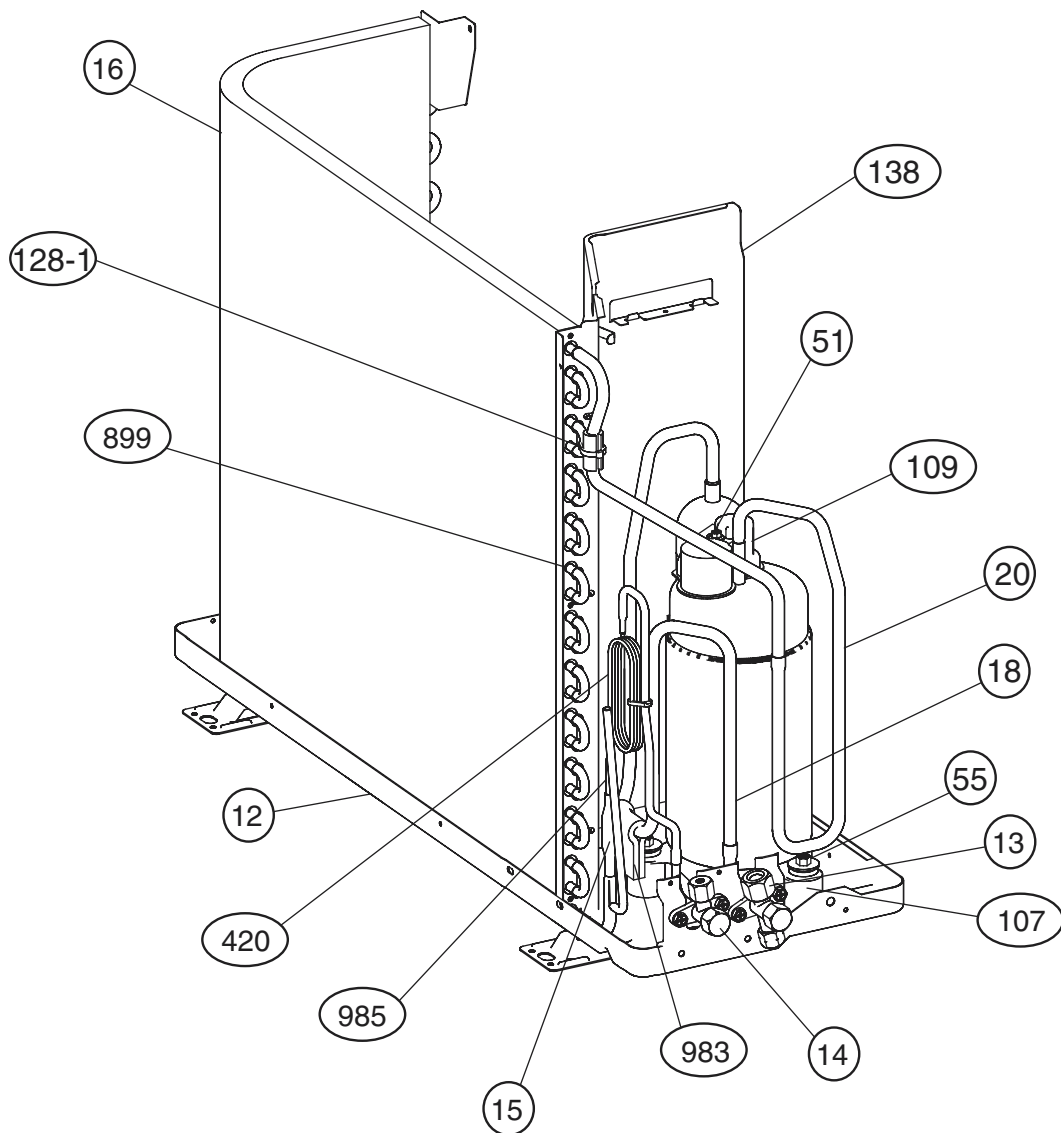

Model : AOG7USAJL

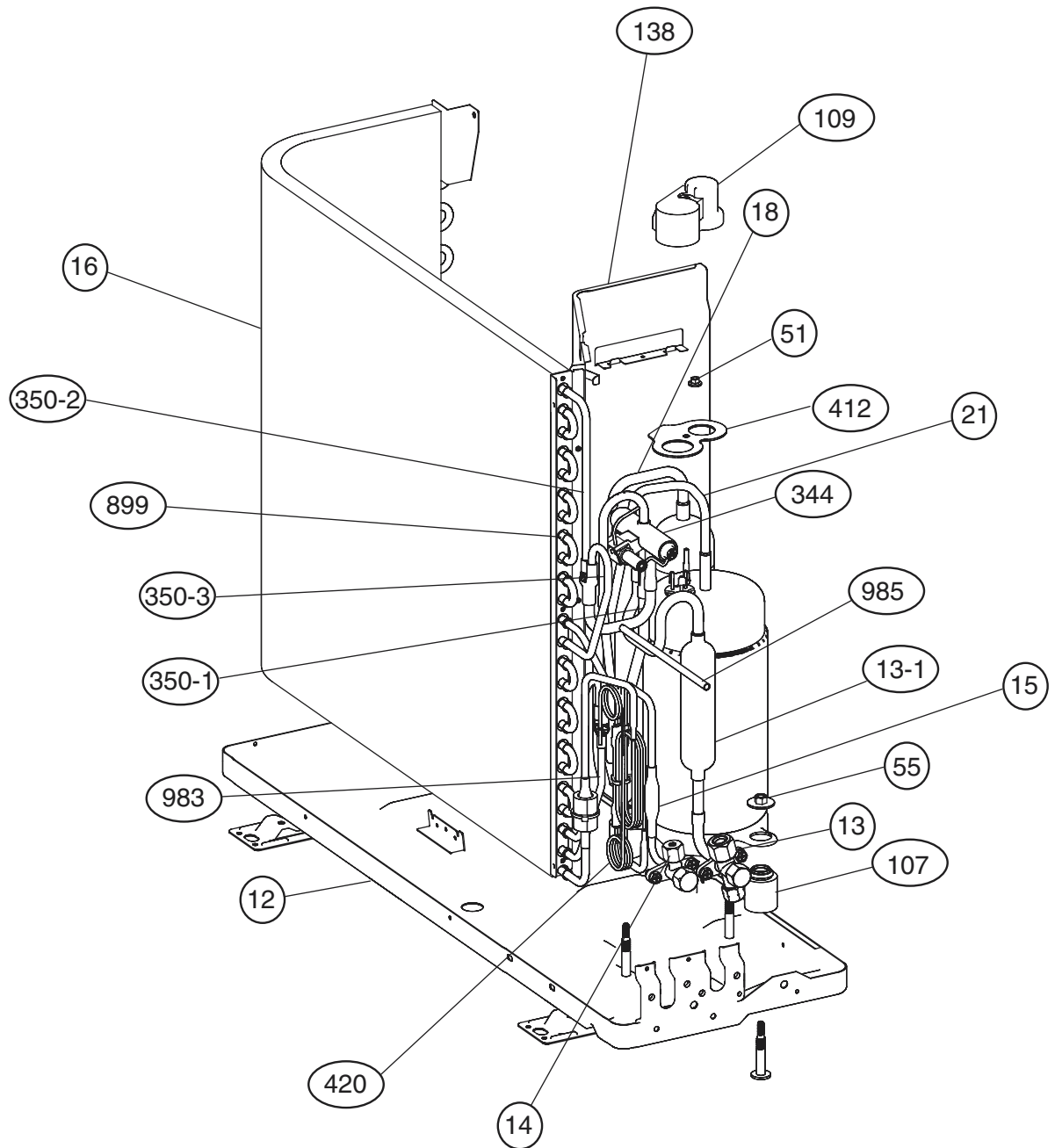

Model : AOG9USAJL

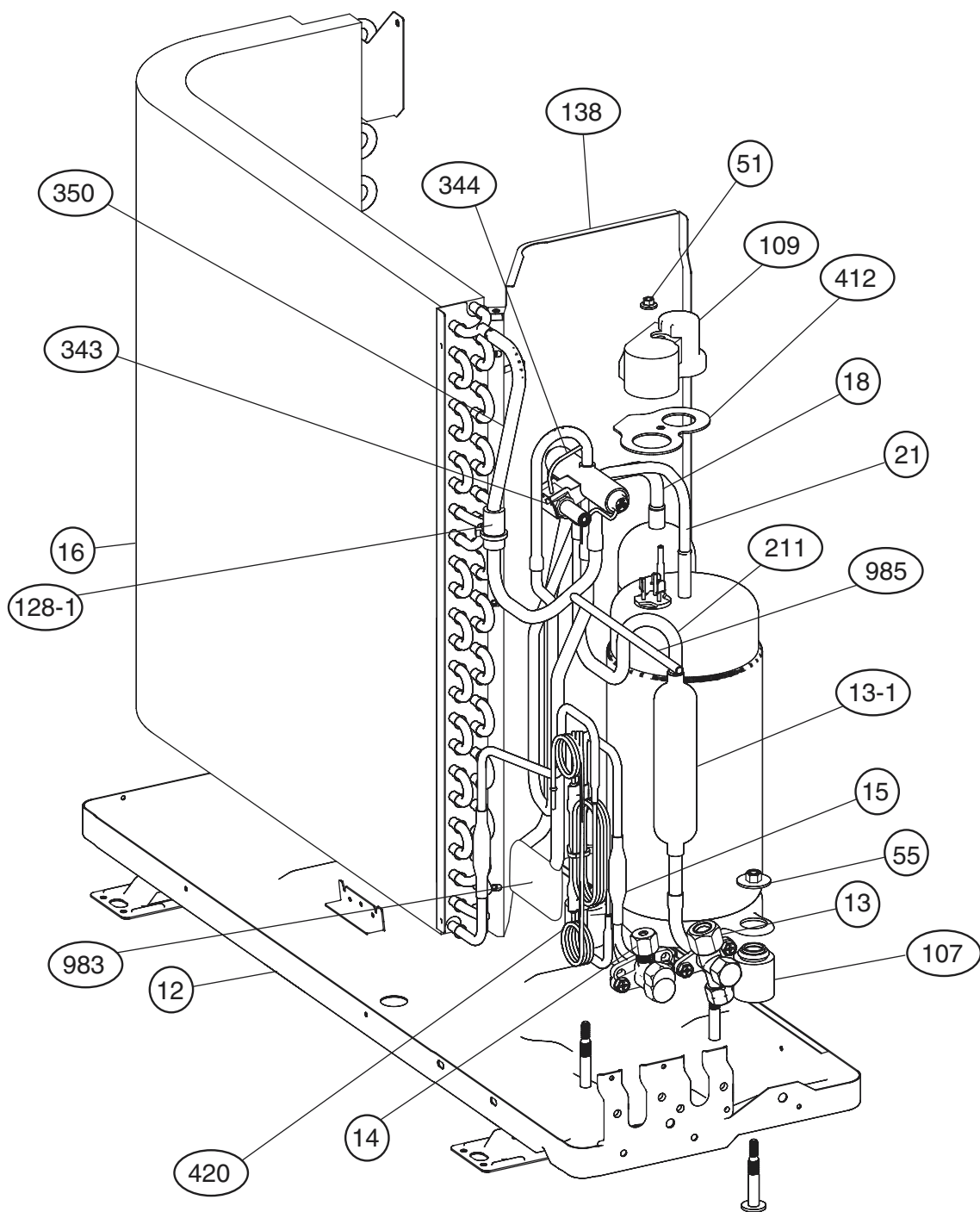

PARTS LIST

When you order parts, please make a photocopy of this page and fill the number of the parts in the "Order" column.

INDOOR UNIT

Ref. No.	Description	Part No.				Ord. Q'ty
		ARG7FUAB	ARG9FUAB	ARG7UUAB	ARG9UUAB	
34	Fan Capacitor	9703306075	9703306075	9703306075	9703306075	
56	Sirocco Fan Assy	9358621004	9358621004	9358621004	9358621004	
63	Panel Assy Front	9363722000	9363722000	9363722000	9363722000	
67	Rubber (Vibration-proof)	313659068604	313659068604	313659068604	313659068604	
74	Air Filter	9366833017	9366833017	9366833017	9366833017	
109	Casing Assy	9363322002	9363322002	9363322002	9363322002	
126	Bracket (Motor) Assy	9358591000	9358591000	9358591000	9358591000	
138	Panel Assy (Motor)	9363193008	9363193008	9363193008	9363193008	
143-1	Clamp NK-3N	313361274700	313361274700	313361274700	313361274700	
146	Evaporator Assy	9373255031	9373255031	9373255031	9373255031	
147	Distributor Assy	9373034070	9373034070	9373034070	9373034070	
160	Drain Pan Sub Assy	9364502014	9364502014	9364502014	9364502014	
164	Motor, Induction	9600778203	9600778203	9600778203	9600778203	
173	Hook Metal	9363195002	9363195002	9363195002	9363195002	
184-1	Thermostat Spring-A	313728262708	313728262708	313728262708	313728262708	
195	Binder-C (SKB-100)	313361275805	313361275805	313361275805	313361275805	
196-2	Binder-M (SKB-150)	313035356905	313035356905	313035356905	313035356905	
232	Coupling Pipe Assy	9373038078	9373038078	9373038078	9373038078	
234	Thermistor (Room)	9703299063	9703299063	9703299063	9703299063	
235	Pipe Thermistor	9703297090	9703297090	9703297090	9703297090	
236	Controller PCB Assy	9704329660	9704329677	9704329639	9704329622	
240	Remote Control Unit	9372266021	9372266021	9372266014	9372266014	
244	Cover (Piping)	9363330007	9363330007	9363330007	9363330007	
287	Cap (Power)	9352173011	9352173011	9352173011	9352173011	
320-1	Wire Clamp Metal	313483219905	313483219905	313483219905	313483219905	
338	Bracket (Motor)	9358594001	9358594001	9358594001	9358594001	
380	Locking Spacer KGLS-6S	313209391403	313209391403	313209391403	313209391403	
381-4	Spacer KGPS-6S	0600118075	0600118075	0600118075	0600118075	
455	Control Box	9366299004	9366299004	9366299004	9366299004	
464	Cabinet Cover Sub Assy	9364503011	9364503011	9364503011	9364503011	
514	Control Box Cover	9363201000	9363201000	9363201000	9363201000	
567	Support Plate (Eva.)	9363323009	9363323009	9363323009	9363323009	
588-1	Bracket Eva. R	9363199000	9363199000	9363199000	9363199000	
588-2	Bracket Eva. L	9363198003	9363198003	9363198003	9363198003	
625	Cord Bush	9359240006	9359240006	9359240006	9359240006	
734	Top Panel Sub Assy	9364507019	9364507019	9364507019	9364507019	
761	Side Panel Right Sub Assy	9364505015	9364505015	9364505015	9364505015	
762	Side Panel Left Sub Assy	9364506012	9364506012	9364506012	9364506012	
815-1	Terminal	9900016036	9900016036	9900016036	9900016036	
815-2	Terminal	9703345012	9703345012	9703345012	9703345012	
875	Filter PCB Assy	9704561176	9704561176	9704561176	9704561176	
982-1	Clamp (Cord)	9356857009	9356857009	9356857009	9356857009	
982-2	Clamp (Cord)-B	9356858006	9356858006	9356858006	9356858006	
—	Relay G5NB-1A	9900007010	9900007010	9900007010	9900007010	
—	Relay G5SB-14	9900200015	9900200015	9900200015	9900200015	









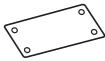

When you order parts, please make a photocopy of this page and fill the number of the parts in the "Order" column.

OUTDOOR UNIT

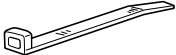

Ref. No.	Description	Part No.				Ord. Q'ty
		AOG7FSAJ	AOG9FSAJ	AOG7USAJL	AOG9USAJL	
2	Guard (Fan)	9304109006	9304109006	9304109006	9304109006	
4	Emblem-Rear	313698088313	313698088313	313698088313	313698088313	
5	Cabinet Painted	9302936017	9302936017	9302936017	9302936017	
7	Cover (Switch) Assy	9389307427	9389307427	9389307427	9389307427	
9	Panel (Rear) Assy	9303017012	9303017012	9303017012	—	
9	Panel (Cabinet Rear) Painted	—	—	—	9303744017	
12	Base Assy, Painted	9310889091	9310889091	9310889091	9310889091	
13	3-Way Valve Assy	9372205020	9372205020	9372205020	9372205020	
13-1	Muffler	—	—	9372369012	9372369012	
14	2-Way Valve Assy	9372204030	9372204030	9372204030	9372204030	
15	Strainer Assy	9366602019	9366602019	9366602019	9366602019	
16	Condenser Assy	9373131052	9373131052	9373131021	9373131038	
18	Suction Pipe-A	9372176177	9372176177	9372176092	9372176108	
20	Discharge Pipe Assy	9371581118	9371581125	—	—	
21	Discharge Pipe-A	—	—	9372179055	9372179062	
32-1	Control Box Metal-A	9355843003	9355843003	9355843003	9355843003	
34	Capacitor, Plastic (Fan Motor)	9900231026	9900231026	9900231026	9900231026	
37	Capacitor, Plastic (Compressor)	9704436016	9704436139	9704436016	9704436139	
38	Clamp Metal (Capacitor)	313468061808	313468061808	313468061808	313468061808	
39	Propeller Fan	9351589011	9351589011	9351589011	9351589011	
—	Hexagon Nut (Spring Lock Washer)	301721150112	301721150112	301721150112	301721150112	
—	Special Washer	301801155013	301801155013	301801155013	301801155013	
41	Motor, Induction MFB-14VTT	9601113010	9601113010	—	—	
41	Motor, Induction MFB-14NTT	—	—	9601113096	9601113096	
42	Bracket (Motor)	313166243804	313166243804	313166243804	313166243804	
51	Special Nut M5	313199233602	313199233602	313199233602	313199233602	
55	Special Nut M8 (For Comp.)	9355091008	9355091008	9355091008	9355091008	
98	Ring (Fan)	313166296109	313166296109	313166296109	313166296109	
105	Compressor Assy	9373010012	9373010029	9373010012	9373010029	
107	Rubber Seat (For Comp.)-A	9351507015	9351507015	9351507015	9351507015	
109	Terminal Cover (Comp.)	9302419008	9302419008	9302419008	9302419008	
128-1	Rubber (Discharge Pipe)	313194159807	313194159807	—	313194159807	
138	Separator Sub Assy	9389331026	9389331026	9389331026	9389331033	
210	Relay EL200/240A1-F(M)-C	9900074012	9900074012	9900074012	9900074012	
211	Joint Pipe Valve-A	—	—	—	9372178041	
—	OCR Assy	9309128002	9311143000	9309128002	9311143000	
343	Solenoid	—	—	9900165017	9900165017	
344	4-Way Valve	—	—	9900162016	9900162016	
350	Inlet Pipe	—	—	—	9372186077	
350-1	Inlet Pipe-A	—	—	9372186060	—	
350-2	Inlet Pipe-B	—	—	9372187050	—	
350-3	Inlet Pipe-C	—	—	9372188064	—	
373	Grip	313166178700	313166178700	313166178700	313166178700	
412	Gasket (Terminal)	9351505011	9351505011	9351505011	9351505011	
420	Capillary Assy	9372197240	9372197257	9372197165	9372197141	
423	Noise Insulation-F	9350944019	9350944019	9353944019	9353944019	
527	Protective Net	9355434003	9355434003	9355434003	9355444002	
734	Panel (Top) Assy	9389306024	9389306024	9389306024	9389306031	
764	Drain Cap	—	—	313166024302	313166024302	
765	Drain Pipe (L-Type)	—	—	9301102000	9301102000	
766	Drain Packing	—	—	9301143003	9301143003	
815	Terminal-5P	9900203023	9900203023	—	—	
815	Terminal-8P	—	—	9900203047	9900203047	
899	Bracket (Condenser)	9373054016	9373054016	9373054016	—	
982-1	Clamp (Cord)	9356857009	9356857009	9356857009	9356857009	
982-2	Clamp (Cord)-B	9356858006	9356858006	9356858006	9356858006	
983	BR Sheet B	9351990022	9351990022	9351990022	9351990022	
985	Process Pipe	9372331019	9372331019	9362875004	9362875004	
—	Check Valve	—	—	9372198018	9372198018	
—	Panel (Condenser)-L Up	9373052029	9373052029	9373052029	9373052012	
—	Panel (Condenser)-L Lower	9373053026	9373053026	9373053026	9373053019	
—	Panel (Condenser)-R	9373051022	9373051022	9373051022	9373051015	

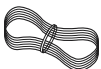
STANDARD ACCESSORIES

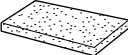
INDOOR UNIT ACCESSORIES

Name and Shape	Q'ty	Application	Parts No.
Installation template 	1	For positioning the indoor unit	9364225005
Hook metal 	4	For suspending the indoor unit from ceiling	9363195002
Tapping screw (ϕ 4 x 10) 	8	For installing the hanger	301171164104
Special nut A (large flange) 	4	For suspending the indoor unit from ceiling	313005446653
Special nut B (small flange) 	4		313005446759
Coupler heat insulation (large) 	1	For indoor side pipe joint (large pipe)	9350716029
Coupler heat insulation (small) 	1	For indoor side pipe joint (small pipe)	9352766015
Binder 	(Small) 1	For remote controller and remote controller cord binding	313361275805
	(Large) 4	For fixing the coupler heat insulation	312300787605
Remote control unit 	1	Heat & Cool model	9372266014
		Cool model	9372266021
Remote controller cord 	1	For connecting the remote controller	9372714010
Tapping screw (ϕ 4 x 16) 	2	For installing the remote controller	0700181108
Filter 	3		9366833017
Drain hose insulation 	1	Insulates the drain hose and vinyl hose connection	313806217708

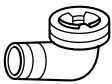
OUTDOOR UNIT ACCESSORIES

Name and Shape	Q'ty	Application	Parts No.
Drain pipe 	1	For outdoor unit drain piping work [Heat & cool model (Reverse cycle) only]	9303029015
Drain cap 	1		313166024302

